



Shear Grabs | Block Cutters



The **NC** range of Shear Grabs are both powerful and durable. With a range of 8 sizes (1.3m - 2.3m) it has been designed to suit all types of farms from large scale dairy to modest small holdings.

The powerful hydraulic cylinders are built to the most stringent industrial standards. The rods are nickel-plated prior to chroming ensuring extensive anti-corrosion protection against chrome flake and rust, and also prevents damage to the hydraulic seals.

Powered by these high quality nickel chromed hydraulic rams they have a uniquely designed blade (made from hardened steel) which will effectively cut silage blocks with minimum power requirements. Designed to stay sharp, the blades leave a sealed pit face, which eliminates secondary fermentation. For added safety, the sharp blades are protected by two robust stops, which stop the knife from coming into contact with the ground.

The bushed beam provides individual support for each of the tines and extra support for the edge tines. This ensures minimal wear and a long working life. They are fitted with wear plates which protect the beam from being worn over time.

The cranked tines allow for easy unloading of the cut block.

On triple ram models a centre knife divides the block into 2 equal sections for feeding.



WHERE QUALITY COMES FIRST



Shear Grabs | Block Cutters



With a wide range of bolt on front end loader and industrial brackets they can be fitted to Tractor or Skid Steer Loaders, Telescopic Handlers or Industrial Loaders.

Model	Cutting Width (A)	Max Block Height (B)	Tine Length (C)	Max Overall Height (D)	Number of Tines	Tine Spacing (E)	Number of Rams	Ram Size	Centre Blade	Capacity
1.3m	1300mm (4'3")	800mm	820mm	1430mm	10	132mm	2	90mm Bore	NA	0.83m ³
1.5m	1500mm (4'11")	800mm	820mm	1430mm	11	140mm	2	90mm Bore	NA	0.96m ³
1.7m	1700mm (5'7")	800mm	820mm	1430mm	13	132mm	2	100mm Bore	NA	1.10m ³
1.9m	1900mm (6'3")	800mm	820mm	1430mm	14	138mm	2	100mm Bore	NA	1.23m ³
1.9m	1900mm (6'3")	800mm	820mm	1430mm	14	138mm	3	90mm Bore	Standard	1.20m ³
1.9m	1900mm (6'3")	800mm	820mm	1430mm	16	119mm	3	90mm Bore	Standard	1.20m ³
2.1m	2100mm (6'10")	800mm	820mm	1430mm	16	132mm	3	90mm Bore	Standard	1.33m ³
2.3m	2300mm (7'6")	800mm	820mm	1430mm	18	130mm	3	100mm Bore	Standard	1.47m ³

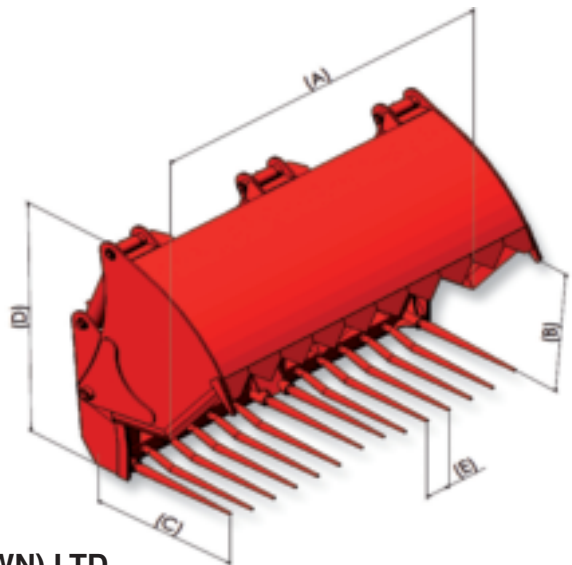

NC ENGINEERING (HAMILTONSBAWN) LTD

2 Killyrudden Road, Hamiltonsbawn, Richhill, Co. Armagh, N. Ireland BT61 9SF

Tel: 028 3887 1970 Fax: 028 3887 0362

E.mail: info@nc-engineering.com website: www.nc-engineering.com

In accordance with our policy of continued development we reserve the right to alter specifications and designs without notice