



Grain/Silage Trailers



HARDOX[®]
WEAR PLATE

“Unrivalled strength
to weight ratio”

www.nc-engineering.com

Standard Specification

- Chassis designed using latest 3D software and finite element analysis
- 10-stud commercial axles c/w 420 x 180 brakes and manual slack adjusters
- Hydraulic brakes giving minimum 35% efficiency
- Sprung drawbar c/w heavy duty EN16 towing eye
- Mono leaf parabolic suspension at wide centres for maximum stability
- Full width front perspex window and honeycomb cover
- Ratchet Handbrake
- Full R.T.A LED lights c/w twin rear clusters & LED flashers
- Hydraulic up and over grain door complete with hydraulic safety latch and rubber seal
- 70mm taper on body
- Rope hooks
- Bolt-on mudguards c/w mudflaps
- Sockets for fitting silage sides, roll over cover etc

NOTE: A Grain Chute is an optional extra



Twin tipping cylinders provide stability and raise tapered body to 50° for easy material flow



13 – 20 tonne models with large capacity body. I series trailers are manufactured with a one piece Hardox 450 floor and Strenx chassis rails to optimise strength to weight ratio giving large payloads with a low unladen weight

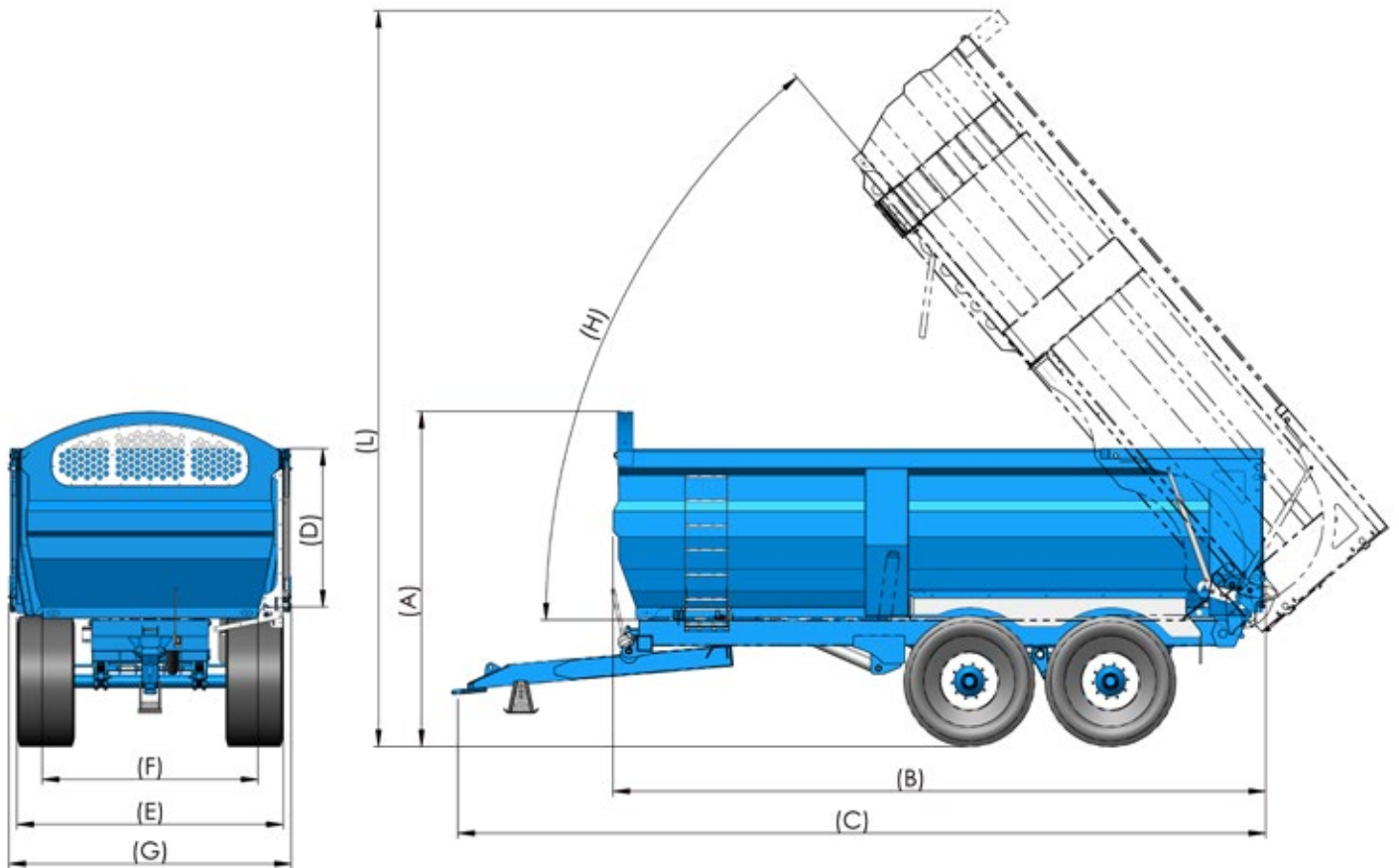

| | | Grain Trailers | | | | |
|--|--------|----------------|--------------|--------------|--------------|--------------|
| | Units | 1650-13 | 1850-14 | 2050-16 | 2250-18 | 2450-20 |
| Overall height body down (A) | m | 3.11 | 3.11 | 3.11 | 3.15 | 3.15 |
| Overall height body down with silage kit | m | 3.65 | 3.65 | 3.65 | 3.69 | 3.69 |
| Body Length (B) | m | 4.88 | 5.49 | 6.1 | 6.71 | 7.32 |
| Overall Length (C) | m | 6.54 | 7.15 | 7.76 | 8.37 | 8.98 |
| Floor to top of side (D) | m | 1.52 | 1.52 | 1.52 | 1.52 | 1.52 |
| Floor to top of side with silage kit | m | 2.44 | 2.44 | 2.44 | 2.44 | 2.44 |
| Width of floor rear (E) | m | 2.12 | 2.12 | 2.12 | 2.12 | 2.12 |
| Width of floor front (F) | m | 2.05 | 2.05 | 2.05 | 2.05 | 2.05 |
| Overall width (G) Inc Hydraulic Door | m | 2.73 | 2.73 | 2.73 | 2.73 | 2.73 |
| Tipping angle (H) | ° | 50 | 50 | 50 | 50 | 48 |
| Overall tipped height (L) | m | 6.18 | 6.73 | 7.01 | 7.59 | 7.88 |
| Overall tipped height with silage kit | m | 6.68 | 7.21 | 7.51 | 8.07 | 8.39 |
| Oil required to tip | Litres | 26 | 34 | 37 | 54 | 54 |
| Number of axles | Qty | 2 | 2 | 2 | 2 | 2 |
| Volume | m³ | 17.2 | 19.4 | 21.5 | 23.7 | 25.8 |
| Volume with silage kit | m³ | 27.5 | 31 | 34.4 | 38 | 41.3 |
| Tyres | Type | 385/65 R22.5 | 385/65 R22.5 | 385/65 R22.5 | 445/65 R22.5 | 445/65 R22.5 |



Access Ladder



Access Ladder
in Transport Position



Rear Door Hydraulic
Locking Mechanism



Twin Hydraulic Rams



Hydraulic Tipping Safety Switch



Sprung Drawbar

Weather Cover



Storage for Weather Cover Winding Handle

Multi Position Grain Chute



Silage Sides

Wheels

| | Description | 1650-13 | 1850-14 | 2050-16 | 2250-18 | 2450-20 |
|----------|-------------------------------------|---------|---------|---------|---------|---------|
| Standard | 385/65 R22.5 Remould | • | • | • | | |
| In Lieu | 385/65 R22.5 New | • | • | • | | |
| In Lieu | 385/65 x 22.5 Pirelli IT90 160K M&S | • | • | • | | |
| In Lieu | 445/65 R22.5 Remould | • | • | • | | |
| In Lieu | 445/65 R22.5 New | • | • | • | | |
| In Lieu | 560/45 R22.5 BKT Ridemax | • | • | • | | |
| In Lieu | 560/60 R22.5 Alliance | • | • | • | | |
| In Lieu | 560/60 R22.5 BKT Ridemax | • | • | • | | |
| | | | | | | |
| Standard | 445/65 R22.5 Remould | | | | • | • |
| In Lieu | 445/65 R22.5 New | | | | • | • |
| In Lieu | 560/45 R22.5 BKT Ridemax | | | | • | • |
| In Lieu | 560/60 R22.5 Alliance | | | | • | • |
| In Lieu | 560/60 R22.5 BKT Ridemax | | | | • | • |

Optional Extras

General

Basic Onboard weighing
Roll over cover c/w long winding handle
Rear Tow Hitch and Light Socket
Folding Rear Tow Hitch c/w Light Socket
Fixed rear rescue point
Self steering rear axle
Grain Chute
Grain Chute c/w grain sock
Steel Tool Box
High Level rear lights
3/4" tipping hose in lieu of standard
Spray Suppression in-lieu of standard mudflaps
Side Impact Protection
Rear Underrun
Standard colours NC: Red (RAL 3001),
Green (RAL 6001), Blue (RAL 5005).
For other colours RAL must be specified
Mudflaps on front of trailer
Central greasing points for suspension and axles

Brakes

Dual air hydraulic brakes
Air only brakes
Hydraulic loadsensing
Air loadsensing
12volt ABS c/w Susie
Automatic slack adjusters
ABS ready kit
NC cable breakaway

Revision.04 October 21

In accordance with our policy of continued development we reserve the right to alter specification and design without notice.



NC Engineering (Hamiltonsbawn) Ltd
2 Killyrudden Road
Hamiltonsbawn
Co. Armagh
Northern Ireland
BT61 9SF

Tel: 028 38 871970
Fax: 028 38 870362

www.nc-engineering.com

Brakes continued -

NC electric breakaway
Eurosafe breakaway
Powerbrake in lieu of standard handbrake
Hydraulic brake connection on rear of trailer
Air brake connection on rear of trailer
Premium red and yellow Susie c/w handle grips
(Dual or air brakes only)

Silage Sides

2ft (610mm) x 3ft (914mm) Silage Extension Sides
2ft (610mm) x 3ft (914mm) Silage Extension Sides

Electrics

Reversing camera
2x rear LED work lights
2x rear LED worklights activated by switch as body tips
LED flasher c/w on/off switch & wired into side lights
LED control kit
Side marker lights flashing as indicators

Warning Signs

Long Vehicle signs (legal requirement for tractor & trailer 13m+ in ROI)
EU slowing vehicle warning triangle
Side and Rear Reflective Tape

Towing Eye

Adjustable Hitch (not available with swivel)
K80 weld-on spoon
K80 bolt-on spoon
Bolt-on 50mm agri towing eye
Bolt-on 50mm Commercial towing eye
High hitch point on drawbar (650mm Max)
Towing Eye locking system

Parking Stand

Screw jack (commercial type)
Hydraulic jack

