



# Dump Trailer



# 300 Series Dump Trailer

- Available in 12 – 20 tonne carrying capacities
- Patented tail- door design enables the Dump Trailer to be used with or without the tail-door in operation, without the need for hydraulics
- Side panels manufactured from 5mm thick steel and supported by a continuous horizontal bulge bar to ensure excellent strength to weight ratio
- Body pivot hinge designed to ensure maximum height of discharge. Higher pivot point for easy stockpiling
- Wider and lower construction for better stability and ease of loading with rubber tyred or mini track excavators
- Body can be scraped clean using 6ft (1.8m) bucket



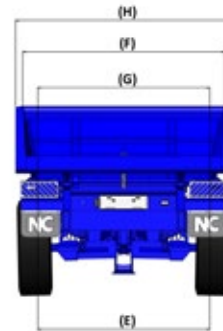
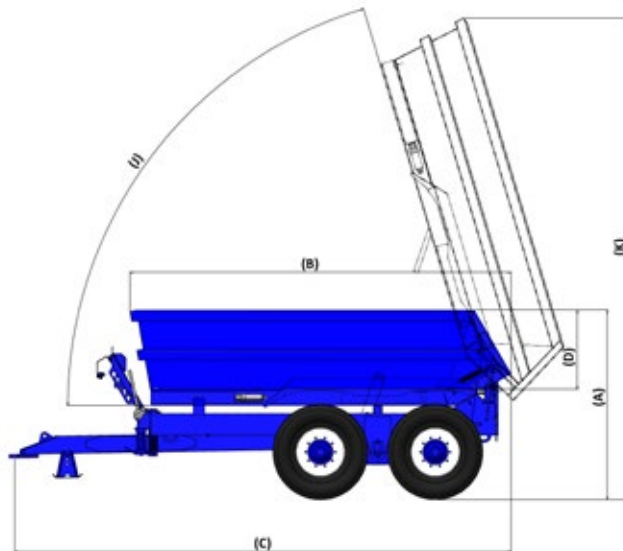

300 Series								
	Units	312 (12T)	314 (14T)	316 (16T)	320 (20T)	320 On 560/60 R22.5	320 On 650/55 R26.5 (Narrow Chassis)	320 On 710/50x26.5 (Narrow Chassis)
Overall Height (A)	m	2.08	2.15	2.22	2.38	2.43	2.56	2.56
Body Length (B)	m	4.19	4.34	4.38	4.78	4.78	4.78	4.78
Overall Length (C)	m	5.40	5.54	5.54	5.94	5.94	5.94	5.94
Floor to top of side (D)	m	0.74	0.82	0.92	1.02	1.02	1.02	1.02
Width of floor (E)	m	2.00	2.00	2.00	2.00	2.00	2.00	2.00
Inside body width at top side (F)	m	2.26	2.28	2.32	2.36	2.36	2.36	2.36
Inside body width at bottom side (G)	m	2.00	2.00	2.00	2.00	2.00	2.00	2.00
Overall width (H)	m	2.46	2.46	2.46	2.66	2.66	2.58	2.69
Tipping Angle (J)	°	73	73	73	72.5	72.5	72.5	72.5
Max height when tipped (K)	m	5.45	5.49	5.58	6.00	6.05	6.18	6.18
Oil required to tip	Litres	26	26	26	41	41	41	41
Number of axles	Qty	2	2	2	2	2	2	2
Floor Thickness	mm	8.00	8.00	8.00	8.00	8.00	8.00	8.00
Side Thickness	mm	5.00	5.00	5.00	5.00	5.00	5.00	5.00
Volume	m <sup>3</sup>	5.70	6.30	7.20	9.00	9.00	9.00	9.00
Draw Bar	Type	Sprung	Sprung	Sprung	Sprung	Sprung	Sprung	Sprung
Axles	Type	80mm 8 Stud	90mm 10 Stud	100mm 10 Stud	127mm 10 Stud	127mm 10 Stud	127mm 10 Stud	127mm 10 Stud
Suspension/Bogie	Type	Oscillating Bogie	Oscillating Bogie	Oscillating Bogie	Tandem Springs	Tandem Springs	Tandem Springs	Tandem Springs
Hydraulic Brakes	Type	350x60	400x80	400x80	420x180	420x180	420x180	420x180
Slack Adjusters	Type	Yes	Yes	Yes	Yes	Yes	Yes	Yes
Tyres	Type	385/65 R22.5	385/65 R22.5	385/65 R22.5	445/65 R22.5	560/60 R22.5	650/55 R26.5	710/50 R26.5

- Available in 12 – 16 tonne carrying capacities
- Hydraulic rear door, folding flat to floor
- Side panels manufactured from 5mm thick steel and supported by a continuous horizontal bulge bar to ensure excellent strength to weight ratio
- Option of 4 metre aluminium ramps with maximum carrying capacity of 6950 kgs on 12-16T models and 4.5 metre aluminium ramps with maximum carrying capacity of 12000 kgs on 20T model
- Storage trays for aluminium ramps integrated into the chassis
- 4 floor hooks inside body for securing loads for safe transportation (eg Mini Digger)
- 6mm Hardox Floor



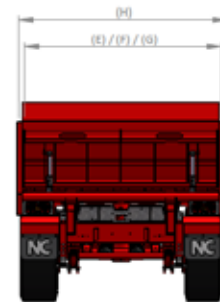
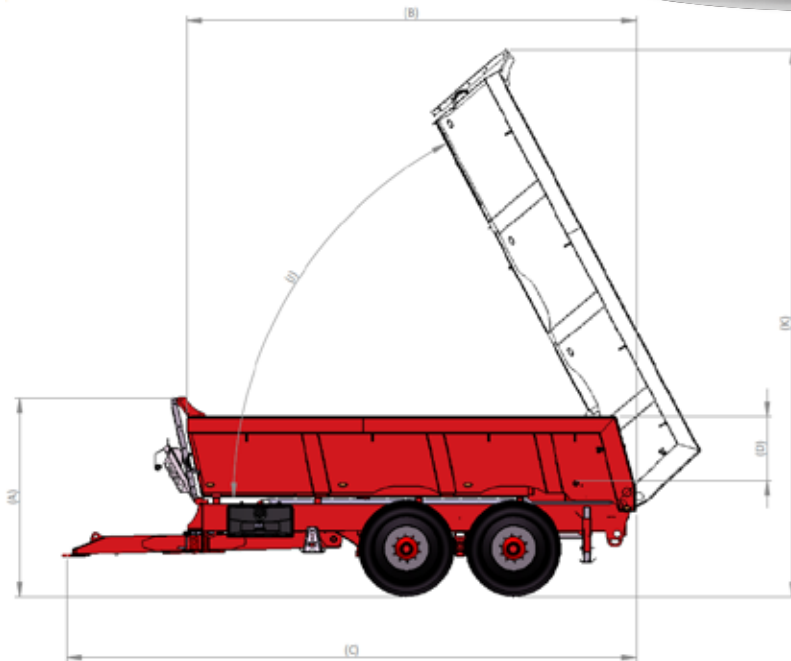

600 Series					
	Units	612 (12T)	614 (14T)	616 (16T)	620 (20T)
Overall Height (A)	m	2.11	2.17	2.20	2.42
Body Length (B)	m	4.96	4.97	4.97	5.49
Overall Length (C)	m	6.34	6.34	6.34	6.95
Floor to top of side (D)	m	0.57	0.64	0.72	0.78
Width of floor (E)	m	2.40	2.40	2.40	2.40
Inside body width at top side (F)	m	2.40	2.40	2.40	2.40
Inside body width at bottom side (G)	m	2.40	2.40	2.40	2.40
Overall width (H)	m	2.54	2.54	2.54	2.54
Tipping Angle (J)	°	67	67	67	62
Max height when tipped (K)	m	6.09	6.14	6.22	6.66
Oil required to tip	Litres	20	28	28	44
Number of axles	Qty	2	2	2	2
Floor Thickness	mm	6 (Hardox - 450)	6 (Hardox - 450)	6 (Hardox - 450)	6 (Hardox - 450)
Side Thickness	mm	5.00	5.00	5.00	5.00
Volume	m <sup>3</sup>	5.90	6.70	7.50	9.00
Draw Bar	Type	Sprung	Sprung	Sprung	Sprung
Axles	Type	80mm 8 Stud	90mm 10 Stud	100mm 10 Stud	127mm 10 Stud
Suspension/Bogie	Type	Oscillating Bogie	Oscillating Bogie	Oscillating Bogie	Tandem Springs
Hydraulic Brakes	Type	350x60	400x80	400x80	420x180
Slack Adjusters	Type	Yes	Yes	Yes	Yes
Tyres	Type	385/65 R22.5	385/65 R22.5	385/65 R22.5	445/65 R22.5



## Specification Table

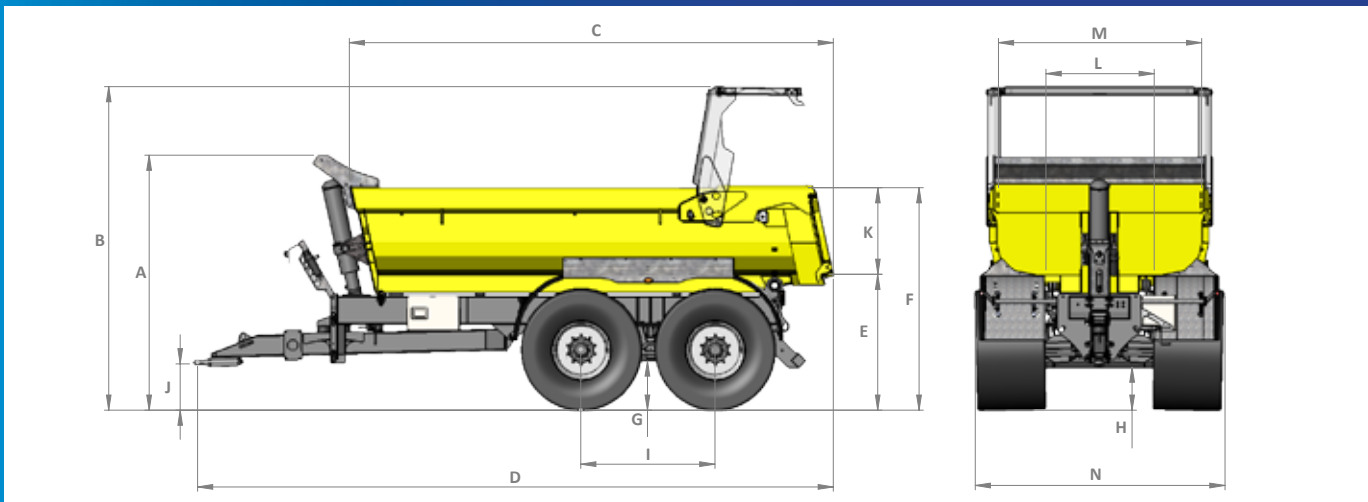

Dump Trailer			
Model 925 (25T)	Units	Metric m	Imperial ft
Overall Height (Transport Position) (A)		2.95	9.67
Overall Height (Rear Door Open) (B)		3.74	12.27
Body Length incl. Rear Door (C)		5.59	18.33
Overall Length (From Centre of Towing Eye) (D)		7.35	24.11
Height of Floor (E)		1.57	5.15
Height of Top of Side (F)		2.57	8.43
Bogie Ground Clearance (G)		0.57	1.87
Rear Underrun Ground Clearance (H)		0.5	1.64
Axle centres (I)		1.55	5.08
Height of Towing Eye (J)		0.53	1.73
Floor to Top of Side (K)		1.00	3.28
Width of Floor (L)		1.25	4.1
Internal Body Width at Top of Side (M)		2.35	7.7
Overall Width (N)		2.89	9.48
Max. Height when Tipped (P)		6.62	21.71
Overall Length when Tipped (Q)		8.69	28.51
Tipping Angle (R)	deg	55°	55°
Oil Required to Tip		43.5 litre	11.49 US gal
Number of Axles	Qty.	2	
Floor Thickness	mm	6	.236 inch
Side Thickness	mm	6	.236 inch
Volume	m <sup>3</sup>	11.3	14.77yd <sup>3</sup>
Drawbar	Type	Cushioned and Adjustable	
Axles	Type	150mm 10 Stud	
Suspension	Type	Oscillating Bogie	
Hydraulic Brakes	Type	410 x 226mm	16.14 x 8.89 inch
Slack Adjusters	Type	Yes	
Tyres	Type	800/45 R26.5	
Unladen weight	Type	7365kgs	8.11 US Ton





- Fabricated heavy-duty chassis
- BPW bogie suspension
- Central greasing system
- Rubber mount cushioned drawbar
- Heavy duty park brake
- Galvanised hose & electric cable rack
- Hydraulic bulkhead connections through chassis
- Heavy duty single hydraulic ram
- Body safety prop (galvanised)
- Heavy duty hinges with greasing points
- Hydraulic brakes on all wheels
- LED low energy lights
- Galvanised covers on taillights
- Stainless Steel lockable toolbox
- 800/45 x 26.5 wheels
- Heavy duty galvanised mudguards
- Dual acting rear hydraulic door
- Heavy duty galvanised front stone guard
- Manual height adjusting Jack
- Swivel hitch (heavy duty)
- Speed rated for 25kph
- Lugs on drawbar for safety chains
- Rear underrun safety protection
- Hardox 450 body





**LED Lights and Galvanised Guards**



**Sprung Drawbar Complete with Galvanised Parking Stand**



**Robot Welded Rocking Bogie**



**Ratchet Park Brake**



**Body Safety Prop**



**600 Series Ramp Storage**



**Automatic Weight Transfer System  
(Standard on 18 & 20 Tonne only –  
Option on 12 - 16 Tonne)**



**Magic Tail Door**

# Options



**Hardox Body**

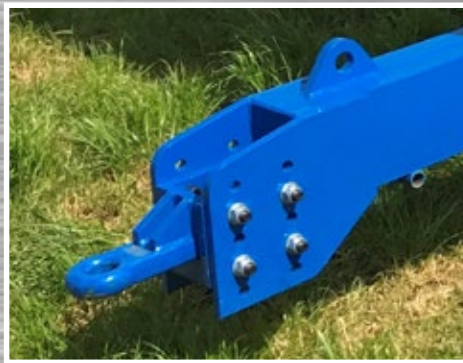

**Adjustable Hitch**



**Powerbrake**



**Weld on Stone Guard**



**Galvanised Bolt on Stone Guard**



**Hydraulic Jack**



**Front to Rear Cover**



**Galvanised Ladder  
(300 Series)**



**Swivel Hitch**



**Galvanised Extension Sides**



**Air & Hydraulic Brakes or Air Only Brakes**



**Galvanised Mudguards**



## Optional extras (All Dump Trailers) to Optional extras (300 and 600 Series)

### 300 Series only -

10mm floor  
12mm floor  
6mm Hardox floor  
8mm Hardox floor  
8mm Hardox door  
12mm Hardox door  
6mm sides  
8mm sides  
6mm Hardox floor and 4mm Hardox sides  
8mm Hardox floor and 6mm Hardox sides  
Stone guard (bolt-on or weld-on)  
8" extension sides (bolt-on)  
Galvanised mudguards  
Galvanised light brackets  
Weight transfer rams (standard on 18 and 20 Tonne)  
Weight transfer rams indicator  
Front ladder

### 600 Series only -

4m long Aluminium ramps rated to 9650kg/pair  
8mm Hardox floor  
5mm Hardox sides

### Optional extras (All Dump Trailers) -

10 Stud axles (400x80 brake) on 12 Tonne  
420x180 high speed axles  
Tandem springs c/w high speed axles  
Front to rear cover (Electric or Hydraulic)  
Toolbox (Steel or plastic)  
Rear tow hitch c/w light socket  
Folding tow hitch c/w light socket  
Rear under run protection  
Spray suppression in-lieu of standard mudflaps  
Side impact protection  
¾" tipping hose in-lieu of standard

Revision 7 – September 2023

In accordance with our policy of continued development we reserve the right to alter specification and design without notice.



NC Engineering (Hamiltonsbawn) Ltd  
2 Killyrudden Road  
Hamiltonsbawn  
Co. Armagh  
Northern Ireland  
BT61 9SF

Tel: 028 38 871970  
Fax: 028 38 870362

[www.nc-engineering.com](http://www.nc-engineering.com)

### Tyres -

New 385/65 R22.5 in-lieu of remould (12-16 Tonne)  
445/65 R22.5  
560/45 R22.5 (12-16 Tonne)  
560/60 R22.5 (16-20 Tonne)  
650/55 R26.5 (20 Tonne only)  
710/50 R26.5 (20 Tonne only)

### Brakes -

Dual air/hydraulic  
Air only brakes  
Hydraulic loadsensing (suspension only)  
Air loadsensing (suspension only)  
12-volt ABS c/w susie (requires high speed axles)  
Automatic slack adjusters (requires high speed axles)  
ABS ready kit (requires high speed axles)  
Cable breakaway  
Electric breakaway  
Eurosafe breakaway  
Powerbrake  
Hydraulic brake connection at rear  
Air brake connection at rear  
Premium red & yellow susies c/w handle grips (Dual or air brakes only)

### Electrics -

Reversing camera  
2 x rear LED work lights  
2 x rear LED work lights activated by switch as body tips  
Dual tail lights (Standard on 600 Series)  
LED flasher (2 loose wires or switch from side lights)  
LED control kit  
Side marker lights flashing as indicators

### Towing eye -

Swivel hitch  
Adjustable hitch (not available with swivel)  
K80 weld-on spoon  
K80 bolt-on spoon  
Bolt-on 50mm agricultural towing eye  
Bolt-on 50mm Commercial towing eye  
Towing eye locking system

### Other -

EU slow vehicle warning triangle  
Side and rear reflective tape  
Painted red, green or blue as standard. All other RAL colours available on request.  
Commercial screw jack  
Hydraulic jack  
Mudflaps on front of trailer  
Central greasing points for suspension and axles

